

IMPORTANT INFORMATION

Slimwasher

IM922 / IM924 / IM925



To be installed by qualified personnel only

Hacel

L I G H T I N G

THE SILVERLINK
WALLSEND
NEWCASTLE UPON TYNE
TYNE & WEAR
NE28 9ND
UK

TECHNICAL: (0191) **280 9914**

FAX: (0191) **263 0946**

E-MAIL: technical@hacel.co.uk

WEB: www.hacel.co.uk

Wiring preparation

1

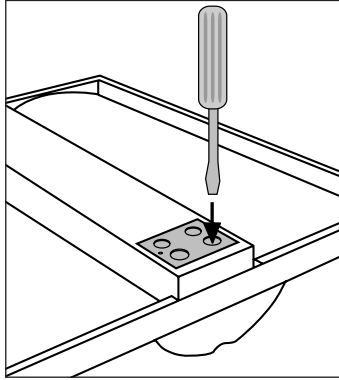

2

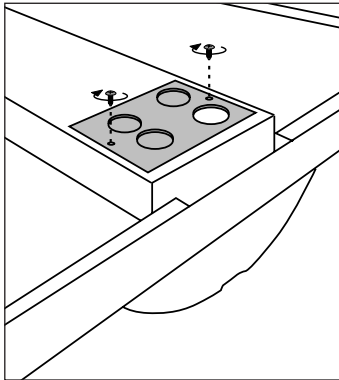

3

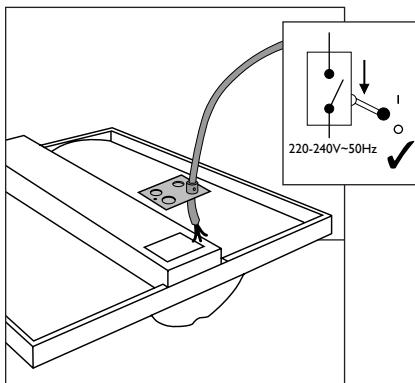

Wiring diagrams

High frequency (D)

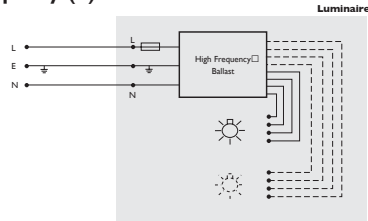

High frequency + Emergency (E)

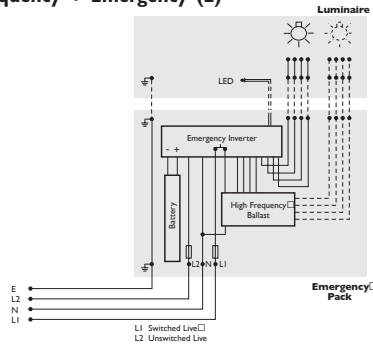

High frequency digital dimming (F)

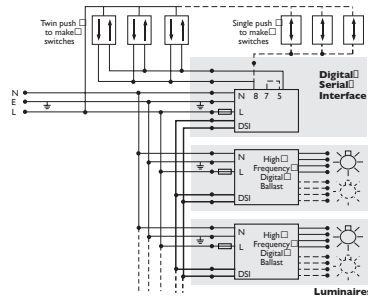

High frequency digital dimming + Emergency (G)

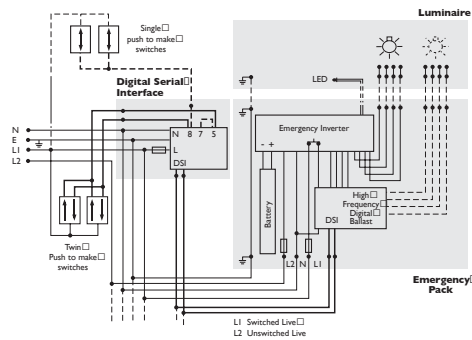

■ High frequency analogue (1-10V) dimming (H)

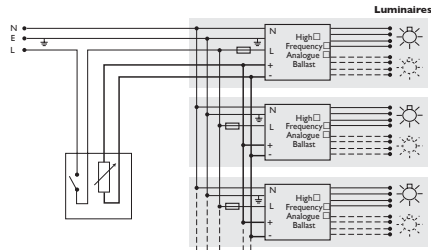

■ High frequency analogue (1-10V) dimming + Emergency (I)

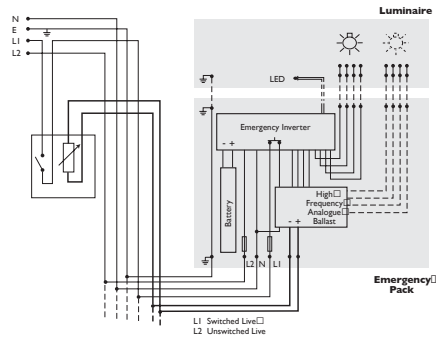

■ High frequency switch dimming (J)

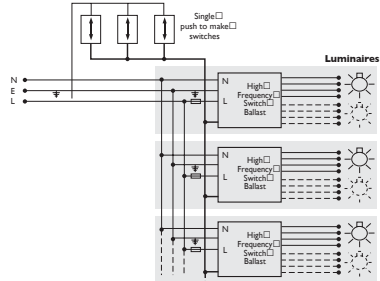

■ High frequency switch dimming + Emergency (K)

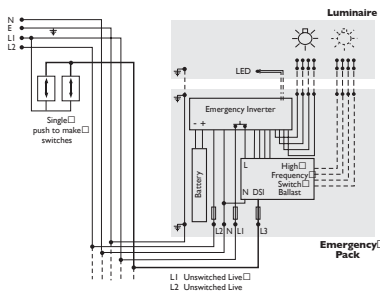

Ceiling installation

1

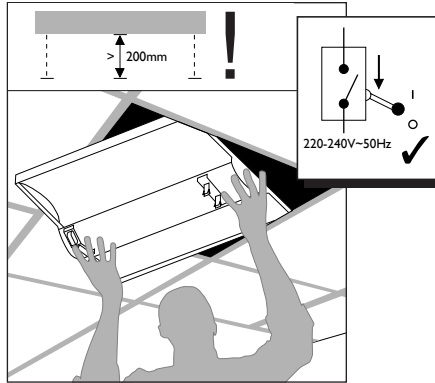

2

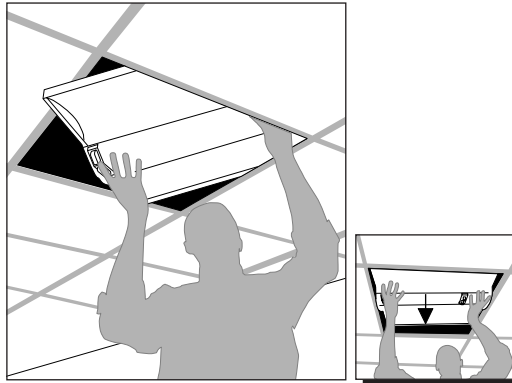

3

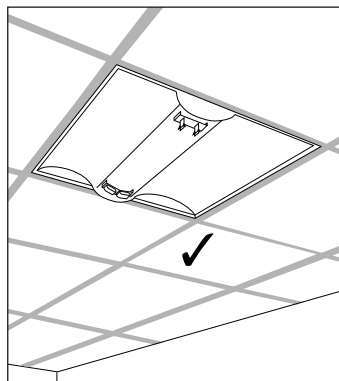

Lamp installation

I

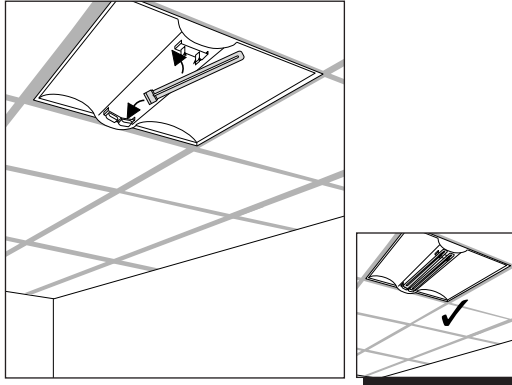

Fascia fixing

I

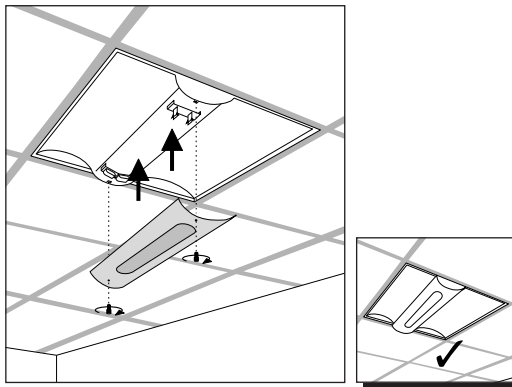

Web: www.hacel.co.uk

TECHNICAL (0191) 280 9914

Ref. 79-0056